

FLUKE®

Biomedical

Nuclear Associates 07-440

Digital Densitometer II with RS-232C Interface

Operators Manual

March 2005
Manual No. 163001 Rev. 3
©2003, 2005 Fluke Corporation, All rights reserved. Printed in U.S.A.
All product names are trademarks of their respective companies

**Fluke Biomedical
Radiation Management Services**

6045 Cochran Road
Cleveland, Ohio 44139
440.498.2564

www.flukebiomedical.com/rms

Table of Contents

Section 1:	General Information	1-1
1.1	Introduction	1-1
1.2	Specifications.....	1-2
Section 2:	Operation	2-1
2.1	General	2-1
2.2	Receiving Inspection.....	2-2
2.3	Setup	2-2
Section 3:	Maintenance and Calibration	3-1
3.1	Periodic Maintenance	3-1
3.2	Aperture Alignment	3-2
3.3	Calibration.....	3-2
3.4	Lamp Replacement.....	3-3
3.4.1	Table Lamps	3-3
3.4.2	Measurement Light Source.....	3-4
3.5	Recommended Spare Parts.....	3-5

(Blank page)

Section 1 General Information

1.1 Introduction

The Model 07-440 Digital Densitometer is designed to measure optical density with high accuracy and reliability. With minimum training, an operator can make the precise, repeatable measurements necessary for accurate photographic film exposure and processing control. At the push of a button, the result of each measurement is transmitted via an RS-232 interface which allows the operator to acquire this data on a computer system.

Solid state dependability together with rugged construction make the instrument exceptionally stable over long periods. Due to the dependability and construction of the instrument, maintenance requirements are minimal.



Figure 1-1. Digital Densitometer II, Model 07-440

1-2. Specifications

Table 1-1. Instrument Specifications

Feature	Specifications
Density Range	0-4.50
Response Time	≤2 seconds at optical density of 3.00
Warm-Up Time	10 seconds maximum
Accuracy	± 0.02 at density of 3.00 with 1 mm aperture
Density Subtraction	Zero control permits density subtraction of up to 4.50 with 3 mm aperture. Minus sign included on display to show negative relative densities.
Zero Control	10 turn control permits exact zeroing with flashing minus sign indicating correct zero to within 0.002.
Zero Drift	Negligible
Spectral Response	Centered at approximately 465 nanometers
Supplied Apertures	3 mm, 2 mm, and 1 mm diameter Aluminum
Throat	210 mm (8.25 in.)
Illuminated Table Area	120 x 140 mm (4.75 x 5.5 in.)
Detector	Silicon diode
Detector Light Source	White LED provides extremely long life with minimum spectral and intensity degradation. Also reduce specimen heating to a minimum.
Readout	Located on measurement arm; three L.E.D. digits with minus sign, 10 mm (0.4 in.) high.
Dimensions (H x W x D)	4.9 in. x 6.3 in. x 13.4 in. (125 mm x 160 mm x 340 mm)
Weight	7.5 lbs. (3.4 kg)
Shipping Weight	10 lbs. (4.3 kg)
Power	Switch Selectable 115 VAC, 50/60 HZ, 15 W 230 VAC Unit available Order #07-440-20 Fuses For 115 VAC - Use 1.0 A, 250 V, AGC Fast Acting For 230 VAC - Use 0.5 A, 250 V, AGC Fast Acting
Operating Conditions	10° C to 40° C (50° F to 104° F) Maximum 90% relative humidity, non-condensing
RS-232C Interface	User selectable baud rates ASCII format
Supplied Accessories	Part No. 010128 Step Tablet for calibration Four #37 lamps One extra O-ring light seal One set of three apertures

Section 2 Operation

2.1 General

1. Select and position the proper aperture (small flat side UP) as outlined in Section 2-3, Set-Up.
2. Set the ZERO control as outlined in Section 2.3, Setup.
3. Place the film over the aperture with the emulsion side up.
4. Press down on the measurement arm as indicated (PRESS HERE) until firm contact is made with the aperture.
5. Read the optical density on the digital display.

NOTE

For high densities and/or small apertures, it may take a second or two for the reading to reach equilibrium.

DENSITY SUBTRACTION

The difference between two densities may be determined as follows:

1. Turn the ZERO control so that it reads zero (flashing minus sign) over the first (reference) film area.
2. Take a reading over a second film area.
3. The relative density, positive or negative, of the second area measured will be indicated on the display.

NOTE

Be sure to check the ZERO (Step 1) before making subsequent readings. Although the zero drift is small, a routine check prevents the possibility of an Incorrect reading if, for example, the ZERO knob has been accidentally disturbed.

RS-232C INTERFACE OPERATION

To perform data transmission over the RS-232 interface, press the SEND button. After the SEND button is pressed, the ASCII character sequence is:

±XXX

For example +3.24 will be received as +324. To correlate this number with optical density, divide by 100.

2.2 Receiving Inspection

Upon receipt of the unit:

1. Check the shipping carton (s) and their contents for in-shipment damage. If damage is evident, file a claim with the carrier and contact the Customer Service Department at Fluke Biomedical, Radiation Management Services 440.498.2564 immediately.
2. Remove the packing material and the tape which secures the measuring arm. Check that all items listed on the packing slip are present and in good condition. If any items are missing or damaged, contact the Customer Service Department at Fluke Biomedical, Radiation Management Services at 440.498.2564.
2. Verify that the following accessories have been received and are in good condition:
 - a. Step Tablet (P/N 010128)
 - b. Four (4) #37 lamps
 - c. One (1) extra o-ring light seal
 - d. One (1) set of three (3) apertures

NOTE

If any of the listed items are missing or damaged, notify the Customer Service Department at Fluke Biomedical, Radiation Management Services 440.498-2564.

2.3 Setup

WARNING



Disconnect the unit from the power supply before removing cover or changing fuses.

POWER

1. Plug the instrument into an appropriate receptacle. Voltage may vary from 100 to 130 V (200 to 260 V) without affecting the accuracy of the readings.
2. Turn the power switch to the ON position. The display should indicate all digits and the table should be illuminated.

ZERO SET

1. Place the supplied 3 mm aperture in position under the photohead, in the depression over the filter light source WITH THE FLAT SIDE UP.
2. Position the ZERO Control fully counterclockwise.
3. Apply pressure to the measurement arm as indicated (PRESS HERE) until it makes firm contact with the aperture. The display should read 0.010 to 0.20 (positive).
4. Turn the ZERO control clockwise until the minus sign (located just above the left hand digit) flashes on and off, indicating an exact zero condition.

BAUD RATE SELECTION

The unit is shipped with the baud rate factory set for 9600, 8 data bits with one stop bit. Use the following procedure to change the baud rate and/or data bits, stop bit, and parity combination.

1. Remove the four (4) screws on white panel containing the power switch.
2. Carefully slide the panel forward to gain access to the dip switches.
3. Position SW1-3 to SW1-6 as indicated in Table 2-1 for the desired baud rate selection.
4. Position SW1-1 and SW1-2 as indicated in Table 2-2 for the desired data bit, stop bit, and parity combination.
5. RS-232 Cable Connections are as follows:
 - a. Pin 2: Transmit
 - b. Pin 3: Receive (Not Used)
 - b. Pin 7: Signal Ground

Table 2-1. Baud Rate Selection

Baud Rate	Switch SW1 - Position			
	6	5	4	3
300	OFF	OFF	ON	OFF
1200	OFF	ON	OFF	OFF
2400	ON	OFF	OFF	OFF
4800	OFF	ON	ON	OFF
9600	OFF	ON	ON	ON

Table 2-2. Data Bit, Stop Bits, and Parity Selection

Selection	Switch SW1 - Position	
	1	2
8 DATA, 2 STOP, NO PARITY	OFF	OFF
8 DATA, 1 STOP, NO PARITY	OFF	ON
7 DATA, 2 STOP, NO PARITY	ON	OFF
7 DATA, 1 STOP, NO PARITY	ON	ON

(Blank page)

Section 3 Maintenance & Calibration

WARNING



Disconnect the unit from the power supply before removing cover or changing fuses.

3.1 Periodic Maintenance

As with any precision measurement instrument, certain precautions and periodic maintenance are necessary.

ROUTINE CLEANING

CAUTION

Do not immerse the Model 07-440 Digital Densitometer. The unit is not waterproof. The unit should be kept clean and free from dirt and contamination. The unit may be cleaned by wiping with a damp cloth using any commercially available cleaning or decontaminating agent.

CAUTION

Keep the underside of the photohead clean using alcohol and soft cloth as required. DO NOT USE, UNDER ANY CIRCUMSTANCES, ANY OTHER SOLVENT.

Periodically check the alignment of the aperture and the photohead, especially if the instrument has been dropped. Inherent mechanical design makes this alignment check easy:

- a. Remove the aperture in use.
- b. Press down on the measurement arm.
- c. Check that the o-ring light seal fits exactly into the depression normally occupied by the aperture.

NOTE

If the arm is out of alignment, perform the procedure outlined in Aperture Alignment.

If the instrument is used to measure halftones:

- a. The 3 mm aperture should be used to reduce the effect of the sampling area.
- b. Take into consideration the effects of the maximum density of silver in the dots and fringes around the dots.
- c. Avoid comparing a soft-edged dot film with a hard-edged dot film.

3.2 Aperture Alignment

The aperture alignment should be checked, as described earlier in this Section, at least once a year. Correct any noted misalignment using the following procedure:

1. Unplug the power cord.
2. Remove the top rear cover by taking out the four (4) screws securing it to the base.
3. Using a 5/32 inch (4 mm) Alien hex wrench, loosen the three (3) screws at the rear of the arm spring, one complete turn. **DO NOT LOOSEN THE THREE (3) SCREWS ON THE ARM ITSELF.**
4. Inspect the o-ring for damage. If damage is evident, replace it.
5. Push the arm down, with the aperture removed, until the o-ring is exactly centered in the aperture holder.
6. Tighten the three (3) spacing screws, alternately, a quarter turn at a time, until they are fast, while still holding the arm down.
7. The arm should now be exactly aligned.

3.3 Calibration

A calibrated quality control step tablet, P/N 07-440-100, is supplied with the instrument at the time of shipment. This tablet has been factory calibrated with the instrument. Although it is calibrated with high accuracy, its primary use is to check for any drift in the instrument supplied with it. To check long term precision of the instrument, the step tablet should be used at least monthly according to the directions on the envelope.

If the instrument is to be calibrated using another standard calibration step tablet, the following considerations should be taken into account:

1. Use a 3 mm aperture and plot indicated readings versus readings on the calibration sheet supplied with the tablet the slope of this line should be exactly 1.00.

2. Using a small screwdriver, adjust the CAL until the desired calibration is achieved. This can be done by drawing the best straight line through the plotted points, with the origin at zero and noting the correction necessary at, for example, a density near 2.50.
4. Put the tablet on a step reading close to 2.50 and adjust the CAL control until the correct reading is shown.

The calibration method is necessary due to the inaccuracy inherent in even the best calibrated step tablets. Assuming a Step Tablet calibration accuracy of to ± 0.01 (or 3% of indicated density) and a perfect densitometer, the errors on a brand new tablet (with no emulsion flaws or wear) would be as shown in Table 3-1.

While the accuracy should be checked once a year, in most cases no CAL adjustment will be necessary.

For quality control purposes, the calibration of the instrument with a film tablet is quite sufficient. However, it should be noted that the slope of the indicated density curve will change if any color shifts are caused by the materials being measured. Although the light source is close to the ANSI standard of typical response of the human eye, it is not exact. Therefore, films which produce a spectral shift may produce consistently higher or lower density readings. In such cases, a calibrated step wedge of the same material as is being measured is necessary to adjust instrument calibration.

3.4 Lamp Replacement

WARNING



Disconnect the unit from the power supply before removing cover or changing fuses.

3.4.1 Table Lamps

The four (4) #37 lamps which provide table illumination have a life expectancy of approximately 1500 hours. #74 lamps can be used in their place to provide greater brilliancy, but average life is only about 500 hours. Use the following procedure to replace the lamps:

1. Remove the two (2) screws holding the plastic table to the case.
2. Carefully lift out the table using the finger slots provided on either side.
3. The lamps will be clearly visible and, being of the wedge base type, can be removed by pulling up on them.
4. Insert the four (4) #37 replacement lamps provided in the spare parts kit supplied at the time of shipment.

NOTE

When inserting new lamps, make sure that the wire contacts are in proper position, otherwise good contact will not be made.

Table 3-1. Step Tablet Accuracy

Tablet Density	Total Tablet Error	Total Error Assuming Instrument Error ± 0.01
0.10	0.01	0.02
0.30	0.01	0.02
0.50	0.02	0.03
1.00	0.03	0.04
1.50	0.05	0.06
2.00	0.06	0.07
2.50	0.08	0.09
3.00	0.09	0.10
3.50	0.11	0.12

3.4.2 Measurement Light Source

WARNING



Disconnect the unit from the power supply before removing cover or changing fuses.

The LED used for photometric measurements is P/No. 65-158. This LED should have an extremely long life. If the LED requires replacement, use the following procedure:

1. Remove the two (2) screws holding the plastic table to the case.
2. Carefully lift out the table using the finger slots provided on either side.
3. Pull off the tabs attached to the wires of the measurement from the printed circuit board.

NOTE

It is best to use pliers on the tabs while pushing down on the printed circuit board.

4. Loosen the screw holding the LED Socket Assembly in the LED/aperture holder and remove the LED Socket Assembly (see Figure 3-1).

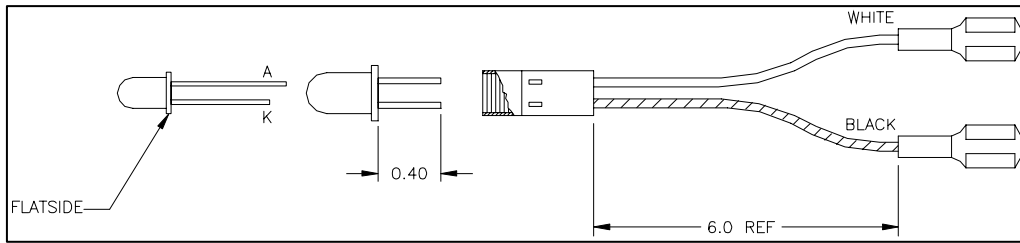

Figure 3-1. LED/Socket Assembly

5. Replace with a new LED, being careful to tighten the LED/Aperture Holder screw only enough to hold the LED Socket Assembly in place. When the LED is properly positioned vertically, it will almost touch the aperture in the holder.
6. Return the light table top to its position on the board and fasten it in place.

WARNING

This instrument contains CMOS Integrated circuits. No service should be attempted unless by a qualified technician thoroughly familiar with CMOS devices. Static charges normally present in a dry atmosphere or leakage current in soldering irons or other non-grounded tools can instantly destroy CMOS integrated devices. Do not attempt to remove or replace any IC sockets without observing anti-static and leakage current precautions.

3.5 Recommended Spare Parts

Recommended spare parts are listed below. Table 3-1 provides a parts lists for the Main Board Assembly and the RS-232 Interface Board Assembly, respectively. Figure 3-1A and 3-1B (RS-232C Interface Board Schematic Diagram), and Figure 3-2 (RS-232C Interface Board Component Layout) are provided for reference.

<u>Description</u>	<u>Part No.</u>
Table Lamps, #37	680011
Measurement LED	65-158
LED Socket Assembly	112327
O-ring, Light Seal	0960013
Aperture Set, 1 ea. 1, 2 & 3 mm	112023
Fuse for 115 VAC, 1 A, AGC,	760001
Fuse for 230 VAC, 0.5 A, AGC,	760004

Table 3-1 RS-232 Board Parts List (112210, Rev B)

Reference	Part No.	Description	Qty.
C1 -19	21-2172-104	CAPACITOR 100000 PF, 50 V, 10%	19
C20,21,26,27	21-2103	CAPACITOR 1 μ F, 25 V	4
C22	201041	CAPACITOR .1 μ F, 12 V	1
C23	201021	CAPACITOR .1000 PF, 500 V, 20%	1
C24,25,28,29	221061	CAPACITOR 10 μ F, -10/+50%	4
C30,31	21-2098	CAPACITOR 56 PF, 300 V	2
J1	67-75-10	CONNECTOR, 10 POS, RT ANGLE	1
J2	92-9102-A	HEADER, P POS, MALE	1
@RESET	92-9041-A	CONNECTOR, 36 PIN, HEADER, M	1
Q1-4	620002	TRANSISTOR MPS-A13	4
R1-4	185-125-4.7K	RESISTOR, 4.7 K, 1/8W, 5%	4
R5-8	185-125-100K	RESISTOR, 100 K, 1/8W, 5%, C-F	4
R9-13	185-125-10K	RESISTOR, 10 K, 1/8 W, 5%, C-F	4
R14	185-3977-3	RESISTOR, 10 M, .25 W, 5%, C-F	1
RP1	185-3974-1	RES NETWORK, 100 K, 8-PIN	1
SW1	92-8006-A	SWITCH, DIP, SPST, 16 PIN. 5A	1
U1,5,8	630061	IC, 74HC74, DUAL D FLIP-FLOP	3
U2,7	630050	IC,74HC00, QUAD 2-IN NAND	2
U3	63-137	IC, 74HC14, HEX INVERTER	1
U6	630062	IC, 74HC04, HEX INVERTER	1
U4	360058	IC, 74HC32, QUAD 2-IN OR	1
U9	63-140	IC, 74HC393, DUAL COUNTER	1
U10	630059	IC, 74HC138. 3 TO 8 DECODER	1
U11	62-465	IC, 74HC20	1
U12	62-436	IC, 74HC221	1
U13-14	64-466	IC, 74HC541	2
U15-17	62-467	IC, 74HC74	3
U18	62-358	IC, 6402 UART	1
U19	62-185	IC, 4702, BIT RATE GENERATOR	1
U20	62-468	IC, 232/RS-232, DIRVER/RECEIVER	1
@U1-9, 11	33-139-14	SOCKET. IC, 14 PIN, PCB MOUNT	10
@ U10,12,19,20	33-139-16	SOCKET. IC, 16 PIN, PCB MOUNT	4
@U13-17	33-139-20	SOCKET, IC, 20 PIN, PCB MOUNT	5
@U18	33-139-40	SOCKET, IC, 40 PIN, PCB MOUNT	1
VR1	640048	IC, LM2931, REGULATOR, + 5 V	1
Y1	92-7012-A	CRYSTAL, 2.456 MHZ	1

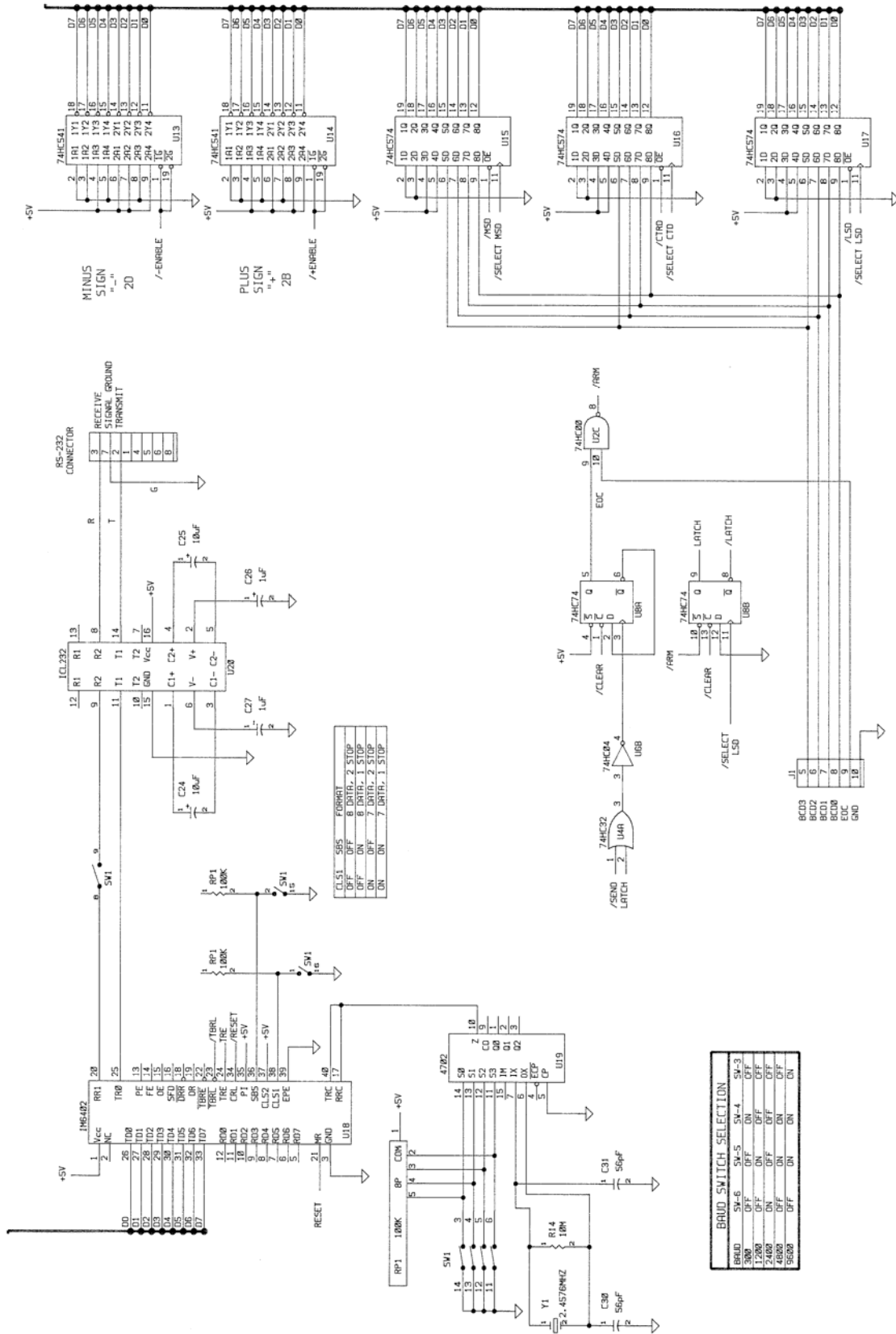

Figure 3-1A. RS232C Interface Board Schematic Diagram (112213, Rev. 2)

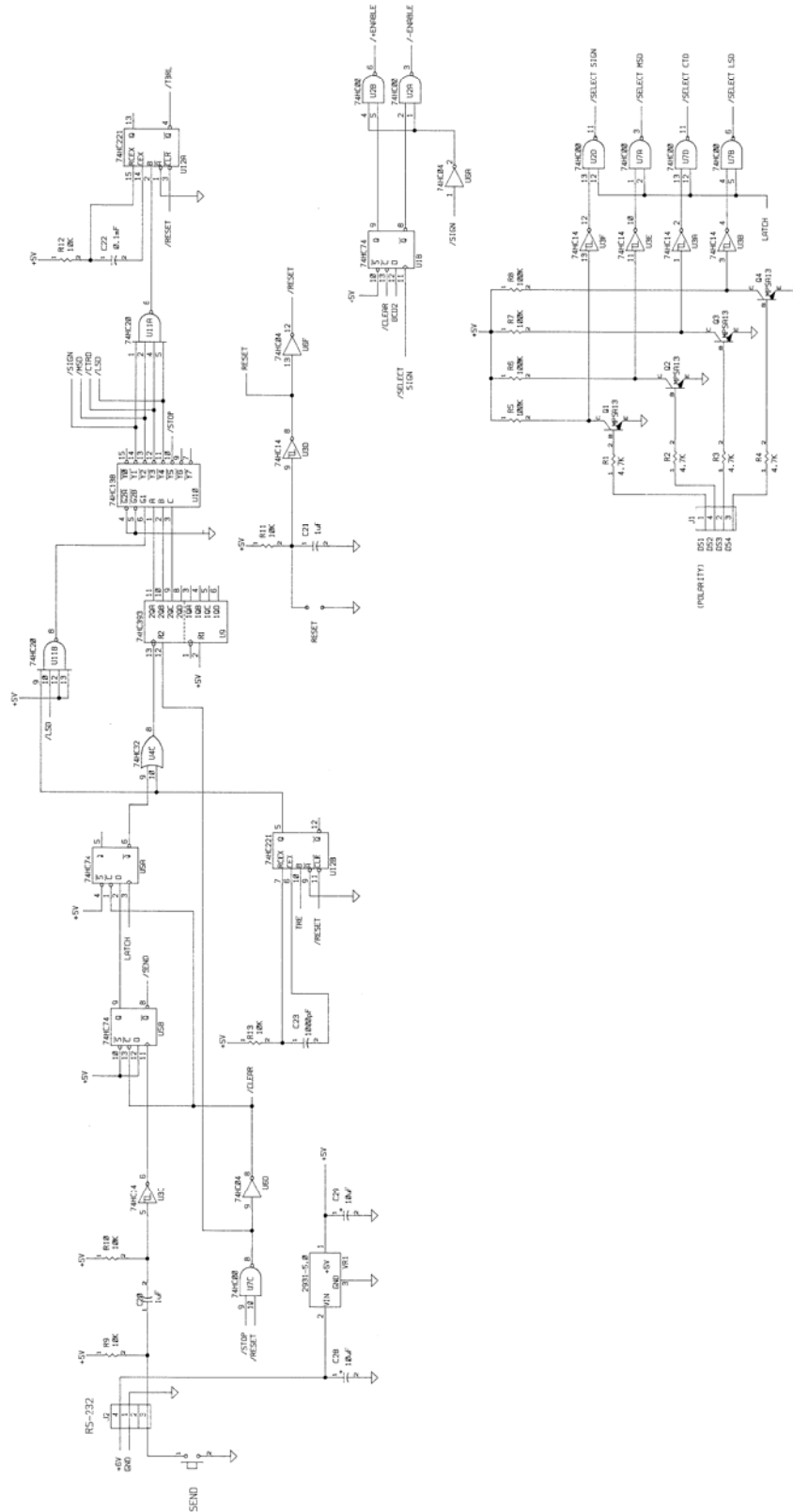

Figure 3-1B. RS232C Interface Board Schematic Diagram (112213, Rev. 2)

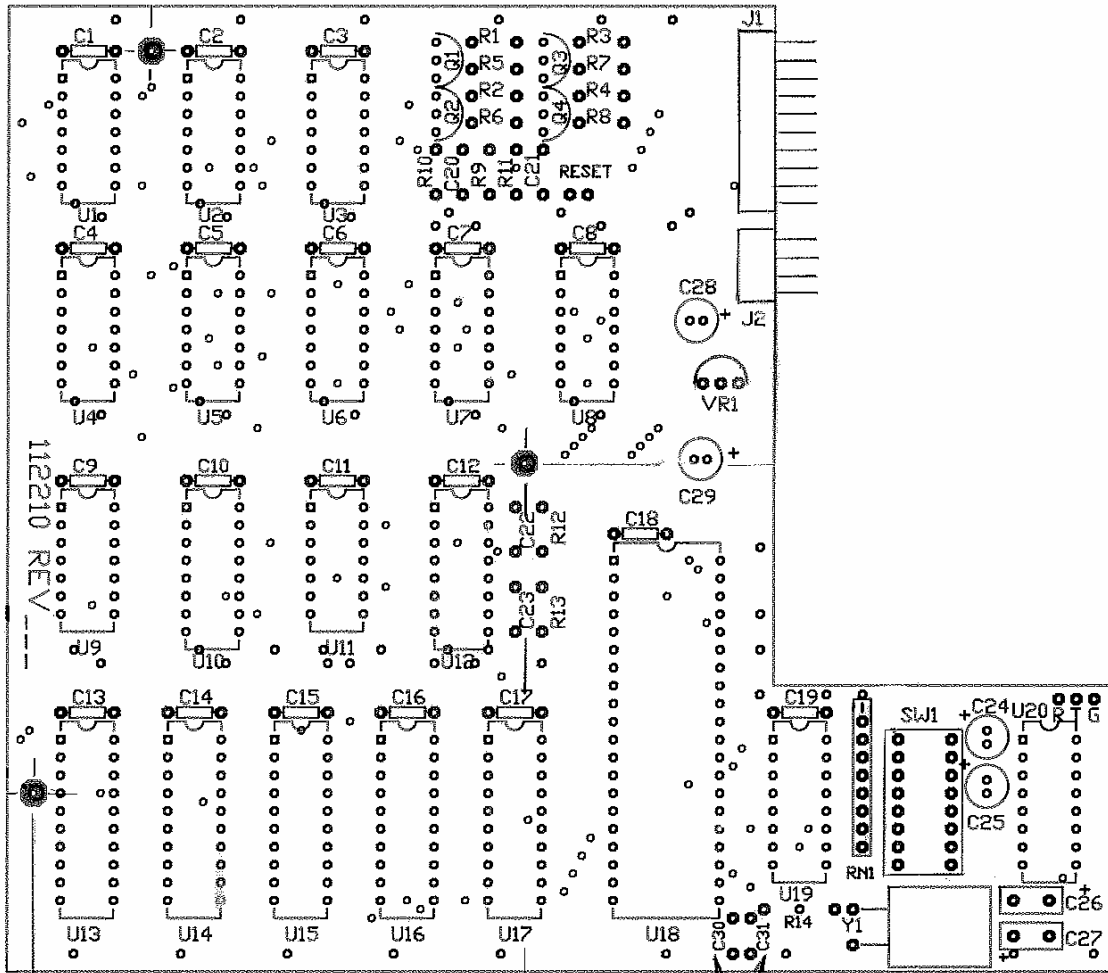

Figure 3-2. RS232C Interface Board Component Layout (112210, Rev. 2)

**Fluke Biomedical
Radiation Management Services**

6045 Cochran Road
Cleveland, Ohio 44139
440.498.2564

www.flukebiomedical.com/rms